

Organizational Agility Capabilities and Sustainable Competitive Advantage in Private Multi-Practice Hospitals in Kenya

John Ngeche* and Veronicah Kaluyu

United States International University-Africa, Nairobi, Kenya

*Corresponding Author's Email: jhngeche@gmail.com

Cite: Ngeche, J., & Kaluyu, V. (2022). Organizational Agility Capabilities and Sustainable Competitive Advantage in Private Multi-Practice Hospitals in Kenya. *The University Journal*, 5(1), 179-194.

Abstract

This study's purpose was to explore the relationship between organizational agility and sustained competitive advantage among Kenyan Private Multi-Practice Hospitals (PMPHs). The study was driven by positivism philosophy and used a descriptive correlational research design. The target population included 690 managers from 46 private level 5 hospitals in Kenya from which a sample of 253 managers was obtained using stratified simple random sampling technique. To gather data, a standardized questionnaire was administered. The collected data were analysed using descriptive statistics (means, percentages, frequencies and standard deviations) and structural equation modelling. The findings from the study established that organizational agility of the PMPHs in Kenya had a significant positive effect on their sustained competitive advantage ($\beta = 0.556$, $CR = 5.158$, $p < 0.05$). There are implications from the study findings for Kenya's private hospital administration to enhance the organizational agility capabilities of their hospitals such as sensing capabilities, leveraging capabilities and reconfiguration capabilities, as an avenue to effectively, and efficiently respond to the complex and dynamic external environment.

Keywords: Kenya, Organizational Agility Capabilities, PMPHs, Sustainable Competitive Advantage

Introduction

In today's complex and dynamic operating environment, coupled with cut-throat competition, the key to organizational success is attaining and sustaining a competitive advantage (Zuñiga-Collazos et al., 2019). Sustainable competitive advantage consists of a company's capabilities and resources that are difficult for competitors to replicate, hence providing a greater long-term advantage (Prabowo et al., 2021). This long-term advantage may be impacted by generic strategies, according to Porter (1985). In addition, Hoffman (2000) and Barney (2002) claimed that the value, imitability, scarcity and organization of a firm's resources are the primary factors of realizing and retaining competitive advantage (Cardeal & Antonio, 2012). Whether internal or external forces are seen as the source of competitive advantage, many schools of thought have emerged (Barney, 2002; Singh et al., 2018). Some researchers like Barney, 1997) and Torres et al. (2018) have conceptualized sustainable competitive advantage from a market-based approach, which sees it as being driven by external variables, whilst others, such as Bharadwaj et al. (1993) and Li et al. (2021), view it from a resource-based model, hence attributing its effect to internal organizational elements. Mahdi and Nassar (2021) note that this divergence in schools of thinking exacerbates the conundrum of precisely what defines a strategy that enables a business to attain and maintain a competitive advantage.

According to various authors, sustained competitive advantage is a prerequisite to survive in this tumultuous environment (Longo et al., 2019; Singh et al., 2020). However, the contemporary dynamic environment imposes limits on the deep-rooted strategic planning and strategy formulation procedures, which are characterized by lengthy study and precise preparation (Sousa, 2010). The hypercompetitive climate has compelled businesses to seek new sources of competitive advantage in a decreasing amount of time (Baskarada & Koronios, 2018). Identified opportunities are unexpected and fleeting (Eisenhardt & Bingham, 2017), which necessitates agility and speed (Appelbaum et al., 2017) since the best plans are ineffective if they take too long to implement (Glassman et al., 2015). Thus, Mazzoni et al. (2021) note that organizational adaptability, is crucial for achieving and maintaining a competitive edge in an environment of complexity, dynamism and cutthroat competition.

Organizational agility is an organization's capability to efficiently and effectively respond to the environmental changes (Hossain et al., 2021). Agility is achieved by reconfiguring ones underlying bases to value create, protect and capture higher yield activities (Teece, Peteratd, & Leih, 2016). Organizational agility is increasingly being realized as paramount to achieving and sustaining competitive advantage (Baskarada & Koronios, 2018; Zitkiene & Deksnys, 2018). This realization is fuelled by an acknowledgement that organizations are generally aligned for internal efficiency rather than agility. In such cases, the organizational processes and structures that traditionally navigated them are no longer fit in the current highly dynamic environment (Kotter, 2014). Organizational agility commits to bridge the inertia gap between organizational addictiveness speed and the environmental volatility speed (Wischnevsky, 2004) and enhances the pursuit of gaining and sustaining competitive advantage (Baskarada & Koronios, 2018; Zitkiene & Deksnys, 2018).

How organizations develop and successfully integrate organizational agility capabilities into their activities remains paramount to sustaining their competitive advantage (Schuiling, 2014; Sune & Gibb, 2015; Yang & Liu, 2012). There is dearth of literature on how organizations integrate agility capabilities into their activities. Moreover, there has not been sufficient or consistent literature in management on the integration of organizational agility capabilities (Singh, Sharma, Hill, & Schnackenberg, 2013). Equally, Appelbaum et al. (2017) noted that most studies seeking to address the concept organizational agility have focused on its characteristics rather than the underpinning organizational capabilities. Further, there lacks a scholarly general consensus in the extant literature on the principal dynamic capabilities underpinning the organizational agility as well as on its exact constructs (Baskarada & Koronios, 2018).

To attain the required levels of agility, an organization must develop its pool of dynamic capabilities so as to cope with the deep uncertainty by enhancing its ability to respond promptly (Eisenhardt & Martin, 2000; Pereira et al., 2018; Sune & Gibb, 2015). In a plausible extension to this view, Worley et al. (2014) added that, agility is the ability to establish, as a repeatable organizational resource, the capability to undertake prompt, effective and sustained organizational change. These effects of agility are supported by dynamic capabilities rationale as an organization ability to expeditiously integrate and reconfigure resources to align to the changing environment to attain and sustain competitive advantage (Teece, 2007). Besides, Baskarada and Koronios (2018) observe that the dynamic capabilities view seeks to describe agility by concentrating on the second order capabilities that enable an organization to adapt its resources.

Statement of the Problem

The volatility, disruptions and complexity in the economic environment has adversely affected the healthcare industry in Kenya, as hospitals face stiff competition within their business ecosystem (Siciliani & Straume, 2019). Approximately 10,000 Kenyans travel abroad annually, predominantly to India and Thailand, for medical treatment despite the country offering 90 percent of the procedures because of patient apprehension of the local healthcare quality and high costs (Mutisya, 2020; Netherlands Enterprise Agency, 2016). This indicates that Kenyan healthcare system is not competitive in comparison with the healthcare systems of other emerging nations. The Kenyan healthcare system comprise of the private and public sectors, with the public sector majorly incorporating mostly government-controlled or owned organizations. The private healthcare sector is made up of commercial or for-profit, non-governmental organization (NGO) and the faith-based organization (FBO) (Muga et al., 1999; NEA, 2016). All the healthcare facilities in the country are subdivided into six tiers based on the amenities and services that they provide. According to Kenya Medical Practitioners and Dentists Council (KMPDC, 2021), level one is the lowest and incorporates healthcare organizations that provides the fewest services, whereas level six has the most. Besides, Mariita (2019) notes that government referral hospitals make up Level 6. KMPDC (2021) observe that Level five is the most competitive and sophisticated for the private sector, with 42 private and four public health care facilities. However, in 2022 level 6 was split into 6A and 6B, where eight of level 5 hospitals that had specialised facilities became 6B and the 2 Level 6B government hospitals plus an addition of 2 others became level 6A (KMPDC, 2022). Hence level 5 in this paper also includes level 6B.

Singh et al. (2020) opine that the disruption and competition in the healthcare sector has affected the private multi-practice hospitals (PMPHs) in Kenya. These hospitals are experiencing fierce competition from a variety of sources, and just having a multispecialty offering is not enough (Cooper et al., 2011). This failure to respond to and manage the changes has resulted in a loss of trust among stakeholders and patients due to poor performance, leading to patient loss to rivals, and the threat of bankruptcy (Agwunobi & Osborne, 2016; Singh et al., 2020). As a result of their failure to meet rising health-care needs, hospitals are fighting to overcome increased competition (Gudwani et al., 2012). In Kenya, a study by the Kenya Healthcare Federation (KHF, 2018) established that, despite having highly specialized equipment, the healthcare system faces challenges such as healthcare financing challenges, insufficient personnel for task completion, as well as ineffective processes all of which directly impede their ability to achieve long-term competitive advantage.

This study thus sought to address the contextual gap of failure or reduced ability of local private multi-practices hospitals in Kenya to attract patients seeking health care outside the country as well as to the local competitors eating into their market share. The findings of the study can be used not only to enhance the perception of PMPHs as the preferred health care service providers in their areas of excellence, but to increase their visibility and to position them for superior performance in an increasingly competitive and globalized market, and in essence enhance their ability to sustain their competitive advantage. Earlier studies have resoundingly affirmed that the principal approach in addressing this advancing competition is to develop SCA (Longo et al., 2019; Porter & Lee, 2013; Shaygan, 2018). It hence becomes vital for PMPHs to be vigilant so as to bolster their capabilities to overcome threats or seize opportunities brought

about by the changes in the healthcare environment (Shaygan, 2018) and to sustain their competitive advantage.

However, there remains a deficit of empirical studies on the future direction of sustainability in the healthcare sector (Rodríguez et al., 2019). Additionally, with the heightened volatility extant literature is void on the current sources of sustained competitive advantage (Singh *et al.*, 2020; Van de Ven et al., 2013). Thus, the study built on the previous work of Singh *et al.*, (2020) that sort to identify sources of sustained competitive advantage in a dynamic environment of hospitals with several medical specialities. In its findings there was emphasis on technology advancement, dynamism and environmental adaptability. However, the study offered insight in the context of India and hence it would be a rich source in understanding the Kenyan context, which faces similar challenges. The following hypothesis is thus developed:

H₀: Organizational agility capabilities have no significant influence on sustainable competitive advantage among PMPHs in Kenya.

Literature Review

Theoretical Review

This study was based on the dynamic capabilities (DC) theory by Teece et al., (1997), which states that the environment is dynamic and competitive, and that companies who are unable to alter their capabilities in response to this are doomed to fail. The theory arose in reaction to the shortcomings of the RBV theory, which failed to conceptualize resources as not only existing, but also having the capacity to be developed and reconfigured (Galvin et al., 2014). The theory outlines how organizations mix, develop, and reconfigure both internal and external organization specific abilities into new competences that are aligned with their dynamic environment (Teece et al., 1997). An organization's existing physical and intangible positions and resource bases, which create organizational processes, are established by the organization's experience and former pathways. It uses its ability to discover and capitalize on opportunities, ultimately enhancing them (Winter, 2013). These capabilities include organizational agility capabilities such as sensing capabilities, leveraging capabilities, and reconfiguration capabilities that enable the organization to attain a strategic fit with the dynamic environment (Karman & Savanevičienė, 2020). It is these new capabilities that can enable an organization create new paths, positions and resource pools which may lead to sustained competitive advantage (Miles, 2012).

Empirical Review

Increased environmental volatility has rendered traditional bureaucratic processes, structures and planned episodic change programs to be unfit in the pursuit of competitive advantage (Appelbaum et al., 2017). The new norm calls for a more agile organization with sensing capabilities that align with speed to the changing forces of the environment. Chen (2019) empirically tested how sensing capabilities are achieved and how in turn they can enhance an organization's competitive advantage. The results established that sensing capabilities in the supply chain had a positive impact on competitive advantage. These findings were in line with Arif et al. (2008), Panayides and Lun (2009) and Swafford et al. (2008) that supply chain sensing capabilities will enhance an organization's competitive advantage. A similar study by Battour et al., (2021) investigated the impact of sensing capabilities on sustained competitive advantage in the context of large and medium sized organizations. The findings showed that

there was a significant direct effect of strategic agility capability of sensing on sustained competitive advantage.

Several scholars have articulated the importance of strategic agility aspect of sensing in enabling organizations to respond soundly to the turbulent environmental conditions (Nejatian et al., 2019; Vecchiato, 2015; Yildiz & Aykanat, 2021). Sensing as a strategic agility is an organization constant ability to detect changes in its environment and effectively adapt the flow of action so as to sustain its competitive advantage (Weber & Tarba, 2014). In line with these views, Battour et al. (2021) investigated the impact of sensing as a strategic agility on sustained competitive advantage in the context of large and medium sized organizations. The findings showed that there was a significant direct effect of sensing strategic agility on sustained competitive advantage. These findings were in line with several previous studies (Ahmad, 2015a; Al-Sa'adi et al., 2017; Baskarada & Koronios, 2018) that supported this outcome.

Hyper-competitive markets brought about by turbulent environments and market complexities have continued to pose a major threat to organizations' survival. Thus strategic agility capabilities of seizing has been posited by scholars as an aegis under strategic management to overcome this threat due to its deemed capability to sustain competitive advantage (Al-daibat, 2017; Al-Sa'adi et al., 2017; Teece et al., 2016). Nurcholis (2019) investigated the effect of organizational agility in terms of seizing capabilities on SCA. The findings showed that seizing capabilities significantly affect sustained competitive advantage. This meant that an organization capability to promptly sense the environmental changes, leverage on the opportunities or address the threats and to adequately reconfigure its resource bases in line with the environment dictates, can directly enhance their competitive advantage sustainability. This findings supported previous research by Weber & Tarba (2014) that posited seizing capabilities as the primary determinant of an organization to sustain its competitive advantage. The findings also concur with Karman and Savaneviciene's (2021) study that similarly found strategic agility capabilities of sensing and seizing to be significantly associated with sustainability practices.

Increased technological changes in the market has necessitated organization to continuously improve their business model efficiency and subsequently develop new solutions to cope with the potential of new threats (Bican & Brem, 2020; Li, 2020). Thus continuous improvement of existing products and services through targeted agility is an exploitation aspect that is pursued by organization in order to respond to market demands (Kohtamäki et al., 2010). Previous research has indicated that seizing as a strategic agility capability enables an organization to meet demands and remain competitive thus enhancing productivity and minimising failure (O'Cass et al., 2014). Additionally, a study by Clauss et al. (2021) established that organizations that seize opportunities by designing business models to satisfy consumers and capture value are able to attain and sustain a competitive advantage. Seizing thus enables organizations to acquire and develop knowledge and information to enable it to take advantage of environmental opportunities while managing threats.

With market uncertainties, understanding agility would be a valuable organisational attribute. Teece et al. (2016) posited that it required an overall model for better comprehension and for that he offered the dynamic capabilities framework. This has contributed to the continued dynamic capabilities consideration when reflecting on the organizational agility. In light of this, Prabowo et al. (2021) explored the effect of reconfiguration capabilities on SCA. The

study's target scope was small and medium organizations in the service and apparel sector. The findings revealed that reconfiguration capabilities have a positive and significant effect on sustained competitive advantage. Another study by Barahmah et al. (2021) examined the effect of strategic agility aspect of reconfiguration on SCA. The study findings revealed that strategic agility has a direct and significant impact on SCA. The findings were consistent with previous studies (Baskarada & Koronios, 2018; Hemmati et al., 2016) that illustrated the compelling impact of reconfiguration capabilities in enhancing the organizations' responsiveness to changes and disruptions in the environment.

Organization's development of unique agile capabilities, such as reconfiguration capabilities act as the basis for sustained competitive advantage. Reconfiguration capabilities are a responsive and dynamic capability that enhances an organization's ability to deal with the turbulent and volatile business environment (Oosthuizen & Scheepers, 2018). Knowledge management is one such organization capability that in configuration with other resources and capabilities leads to sustainability of sustained competitive advantage (Karasneh, 2020). In tandem are other soft capabilities in the organization that are reconfigured to enable an organization to discover and respond to threats and opportunities in the market with ease, speed and dexterity (Tallon et al., 2018). In line with these thoughts, Rafi et al. (2021) investigated the effects of reconfirmation capabilities on organizational performance. In the findings reconfiguration capabilities were found to be positively related to organization performance and sustained competitive advantage. The study also established that the presence of reconfirmation capabilities in an organization positively influences responsiveness of the organization to both internal and external environmental changes.

Conceptual Framework

Figure 1 presents the conceptual framework which illustrates the hypothesized relationships. Organizational agility is a concept that is complex, multidimensional, and context specific, whose capabilities embody the ability to sense environmental changes, and respond quickly to unpredictable change through flexibly reconfiguring resources, knowledge, processes, and capabilities (Yang & Liu, 2012, In Appelbaum et al., 2017). For the purpose of this study, the constructs of organizational agility were sensing, seizing and transformation, as adapted from the dynamic capabilities framework (Teece et al., 2016). Organizational sensing entails the ability of the organization to identify and assess opportunities in the organization's external environment (Teece et al., 2016). Seizing entails mobilizing resources to enable the organization to take advantage of opportunities in the environment (Baskarada & Koronios, 2018). Transforming or reconfiguration capabilities entails the ability of the organization to sustain competitive edge by enhancing, assimilating, protecting, and renewing its resources in line with the state of the environment (Breznik & Lahovnik, 2016). The study's dependent variable was long-term competitive advantage, which was assessed in terms of better product/service quality, accreditation(s), corporate image, and market share (Agwunobi & Osborne, 2016).

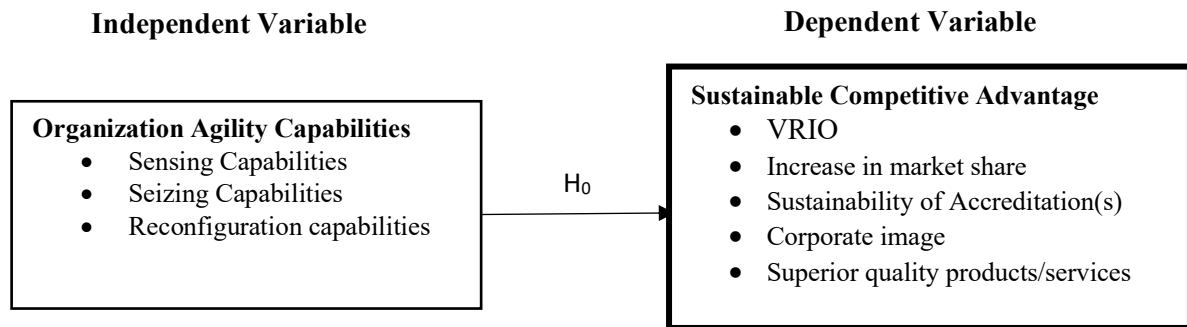

Figure 1: Conceptual Framework

Methodology

The purpose of this study was to describe, explain, and confirm the results of the effect of agility capabilities of PMPHs on their sustained competitive advantage. The study was conducted using a descriptive correlational research design and guided by the positivist research philosophy. The descriptive correlation design as posited by Creswell and Creswell (2018), and Saunders et al. (2016), aided in the testing and explanation of the associations between the agility capabilities and sustained competitive advantage. Besides, Zikmund et al. (2013) argued that correlational design is appropriate when the study seeks to establish a relationship between variables.

The study's target population consisted of 690 personnel recruited from Kenya's 46 level 5 PMPHs that were in Kenya as of March 2021 (KMPDC, 2021). The personnel comprised of ten heads of specialised departments/units, four administrative heads, and the CEO/Administrator of each of the 46 hospitals as the units of analysis. Yamane (1967) sample size formula was used to compute a sample size of 253. The core data for this research was collected using a standardized questionnaire. The findings were summarized using descriptive statistics such as frequencies, means, and standard deviations, while structural equation modelling (SEM) was utilized to examine the impact of organizational agility capabilities on sustained competitive advantage. The Analysis of Moment Structures (AMOS) software version 26 was used for SEM.

Results

Analysis for Organizational Agility Capabilities

The respondents in this study were administered with a total of 253 questionnaires, out of which 215 were correctly completed and returned. This equated to an 85% response rate. Males accounted for 61.9% of those who responded, while females accounted for 38.1%. Besides, 30.7% of respondents were between the ages of 36 and 40, with just 0.5% older than 63. Only 3.3% of survey participants had college diplomas or certificates, whereas the majority (50.7%) held postgraduate degrees. Furthermore, 39.1% of respondents had worked in PMPHs for between 6 and 10 years, while just 2.8 percent had worked in PMPHs for more than 20 years. Moreover, the majority of responders (65.6%) were department directors, and 6.5 percent were administrators or CEOs. Furthermore, the majority of respondents (71.2%) had worked in their roles at PMPHs for less than five years, while those who had worked in PMPHs for more than 16 to 20 years were just 0.9%.

On a five-point Likert scale, the prevalence of organizational agility capabilities in the PMPHs was analyzed (strongly disagree to strongly agree). The responses were analyzed using means (M) and standard deviations (SD). According to the descriptive data in Table 1, the majority of respondents believed that their PMPHs displayed organizational agility capabilities in all three aspects evaluated. Leveraging competencies (M = 4.11, SD = 0.514) were the most prevalent followed by sensing capabilities (M=4.05, SD = 0.449), and then reconfiguration competencies (M = 3.98, SD = 0.522). The standard deviations were all below 1, suggesting that there were little differences between the averages.

Table 1: Descriptive Statistics for Organizational Agility Capabilities

| Constructs | Minimum | Maximum | Mean | Std. Deviation |
|------------------------------|----------------|----------------|-------------|-----------------------|
| Sensing Capabilities | 2.80 | 5.00 | 4.0474 | .44949 |
| Leveraging Capabilities | 2.50 | 5.00 | 4.1147 | .51359 |
| Reconfiguration capabilities | 2.71 | 5.00 | 3.9841 | .52237 |

Confirmatory Factor Analysis and SEM for Organizational Agility Capabilities

The purpose of the CFA in the analysis was to determine how well the observed data matched the pre-specified empirical model. The model was found to be well-fitting ($\chi^2/df = 2.904$, RMSEA=0.049, GFI=0.917, CFI=0.931). The fitness of the model I plied that the data was appropriate to be fitted for SEM. However, before SEM, diagnostic tests that included linearity tests, test of outliers, heteroscedasticity test and test of the normality of residuals were undertaken and all the tests indicated that the model assumptions were met. Thus, SEM was used to evaluate the effect of organizational agility capabilities (OAC) on sustained competitive advantage (SCA). Sensing capabilities (SC), leveraging capabilities (LC), and reconfiguration capabilities (RC) were the latent variables in the path diagram. Figure 2 shows that, according to the fitted structural equation model, a unit change in organizational agility capabilities (OAC) leads to a corresponding 0.56 change in sustainable competitive advantage (SCA). The R-squared ($R^2 = 0.31$) implied that organizational agility capabilities explained 31% of the variation in sustainable competitive advantage of PMPHs in Kenya.

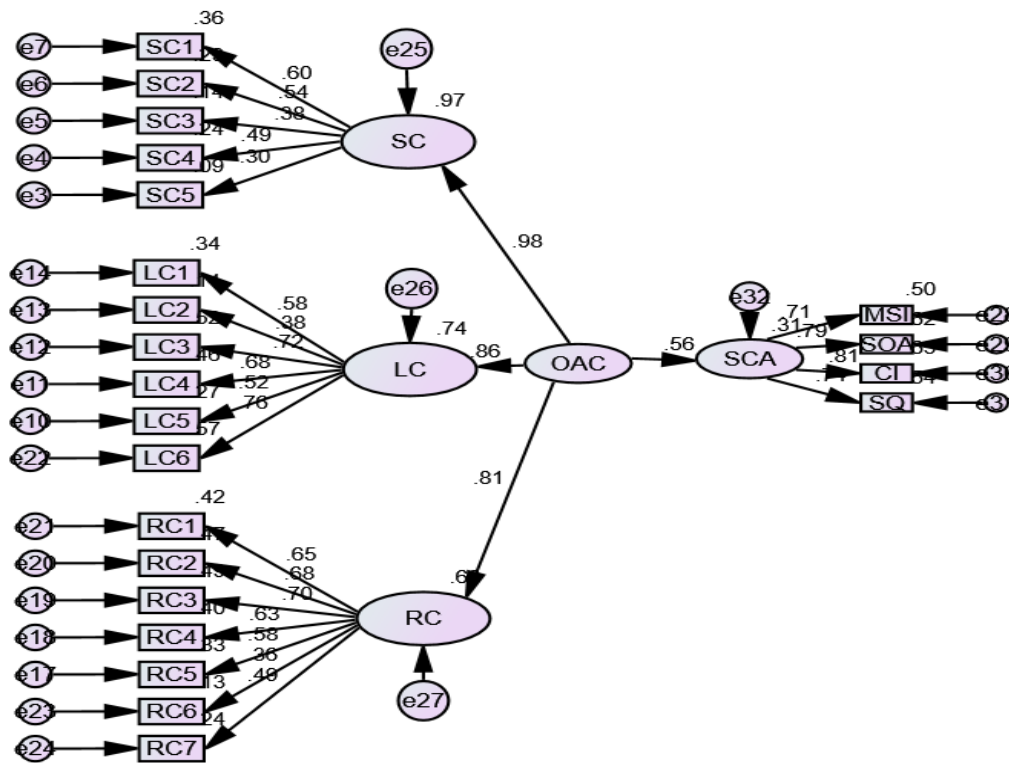

$\chi^2 = 383.277$; $DF=132$; $CFI=0.931$; $GFI=0.917$; $RMSEA=0.049$

Figure 2: SEM for Influence of Organizational Agility Capabilities on Sustainable Competitive Advantage

The study also generated the SEM model's standardized regression weights and estimates which are provided in Table 2.

Table 2: Regression Coefficients for Organizational Agility Capabilities on Sustainable Competitive Advantage

| Relationship | Estimate | Beta | S.E | CR | P |
|--------------|----------|------|------|-------|-------|
| Intercept | .309 | | .181 | 1.702 | 0.090 |
| SC <--- OAC | .596 | .982 | .167 | 3.573 | 0.000 |
| RC <--- OAC | 1.000 | .813 | | | |
| LC <--- OAC | .826 | .862 | .155 | 5.319 | 0.000 |
| SCA <--- OAC | .652 | .556 | .126 | 5.158 | 0.000 |

Table 2 shows that organizational agility capabilities (OAC) and sustainable competitive advantage (SCA) have a positive and statistically significant relationship (Beta = 0.556, CR=5.158, p 0.05). As a consequence, the study’s null hypothesis was rejected. The findings also show that a one-unit change in organizational agility capabilities leads to a corresponding change of 0.556 in PMPHs' sustainable competitive advantage. The regression equation that resulted from the SEM was;

$$\text{Sustained Competitive Advantage} = 0.309 + 0.556 \text{ Organizational Agility Capabilities} + \varepsilon$$

The implication from this regression equation is that when a private hospital has no organizational agility capabilities, its sustainable competitive advantage will be 0.309. Furthermore, an improvement in organizational agility capabilities would lead to an improvement in the hospitals sustained competitive advantage.

Discussion

This study determined that organizational agility capabilities had a significant positive influence on sustainable competitive advantage among PMPHs in Kenya. These findings support the dynamic capabilities theory which, according to Teece et al. (1997), hypothesizes that an organization is able to adapt to the changing environment by developing its resource and agility capabilities portfolio, based on the sequences of path dependent processes. Besides, the findings concur with the observation by Winter (2013) that through reconfiguration capabilities, organizations are able to form new capabilities that enable it to achieve congruence with the dynamic environment and hence attain sustainable competitive advantage. Another previous study with similar findings to the findings from this study is by Appelbaum et al. (2017) which determined that increased environmental volatility calls for a more agile organization that align with speed to the changing forces of the environment, thereby providing it with sustainable competitive advantage. Besides, the study by Appelbaum et al. (2017) determined that organizational agility and transformation are integral factors that enabled firms to attain sustainable competitive advantage, organizational performance and organizational survival.

Dagnino et al. (2020) also had similar findings to those in this study that fast response and constant innovation are primary underpinnings and sources of sustainable competitive advantage. Moreover, the results also agreed with the results by Srivastava et al. (2013) that firms could attain sustained competitive advantage through their capability to develop a set of unique competences such as sensing, seizing and reconfiguration. Another study by Chen (2019) established that agility in this case in the context of supply chain had a positive impact on competitive advantage. The findings from this study are in line with Arif et al. (2008), Panayides and Lun (2009) and Swafford et al. (2008) which all determined that supply chain agility will enhance an organization's competitive advantage. The findings from this study are also supported by various scholars such as Nejatian et al. (2019), Vecchiato (2015) and Yildiz and Aykanat (2021) who have articulated the importance of strategic agility capabilities in enabling organizations to respond soundly to the turbulent environmental conditions. The results from this study also concur with Battour et al. (2021) that there is a significant direct effect of strategic agility on sustained competitive advantage. The findings from this study are also in support with several previous studies such as Ahmad (2015a;), Al-Sa'adi et al. (2017) and Baskarada and Koronios (2018) which all determined that organizational agility was vital for sustainable competitive advantage of the modern organization.

Conclusion and Recommendations

The findings from this study lead to the conclusion that capabilities of PMPHs in organizational agility are essential to attain and sustain a competitive edge. Furthermore, the findings imply that in the healthcare industry, sensing, leveraging, and reconfiguring capabilities are critical for hospitals seeking a long-term competitive edge over the competition. As a consequence, the findings of this research have significance for executives of PMPHs who want to improve their hospitals' organizational agility skills, such as sensing, leveraging, and reconfiguration. Specifically, top management should lead their hospitals in systematically searching for new

business concepts by continually scanning the environment, bringing together creative and knowledgeable employees in the organization to identify new business opportunities, and linking with external creative and knowledgeable persons to help in identifying new business opportunities. Besides, top management should set a tone at the top that motivates employees to adopt new ways of working, provide room for employees to exploit new opportunities, and continually encourage employees and other managers to promote new visions, goals and ideas. Additionally, top management should enhance the capacity of their hospitals to quickly implement their planned activities with regard to their customers, and respond to changes in products, customers or service needs.

The emphasis of this paper was on the effect of organizational capabilities on PMPHs' long-term competitive advantage in Kenya. While the study yielded valuable results, there are numerous additional areas in which further research is recommended. First, owing to varying resource capacity, these results may not be generalizable to other lower-level PMPHs (Level 1 – level 4). As a result, further study on how the capabilities in organizational agility and their influence on long-term competitive advantage among hospitals in the Level one to level four is recommended. The results emanating from such research would take into consideration the specific character and setting of these lower-level PMPHs, which may have fewer resources than those that were incorporated in this study.

Acknowledgments

The authors would like to express their gratitude to United States International University - Africa for the technical assistance in carrying out this study. The Graduate School of the United States International University in Africa was quite helpful in guiding the authors through this research. Besides, the authors appreciate all the private level 5 hospitals that participated in the study for their priceless input.

References

- Agwunobi, A., & Osborne, P. (2016). Dynamic capabilities and healthcare: *California Management Review*, 58(4), 141–162. <https://doi.org/10.1525/cm.2016.58.4.141>.
- Ahmad, A. (2015). Business intelligence for sustainable competitive advantage. *Emerald Insight*. <https://doi.org/10.1108/s1069-09642015000022b008>
- Al-Sa'adi, A. F., Abdallah, A. B., & Dahiyat, S. E. (2017). The mediating role of product and process innovations on the relationship between knowledge management and operational performance in manufacturing companies in Jordan. *Business Process Management Journal*, 23(2), 1–18. <https://doi.org/http://dx.doi.org/10.1108/RPJ-02-2014-0020>
- Aldaibat, B. (2017). The role of social capital in enhancing competitive advantage. *International Journal of Business and Management Invention*, 6(4), 66–78. https://www.researchgate.net/publication/318682075_The_Role_of_Social_Capital_in_Enhancing_Competitive_Advantage
- Appelbaum, S. H., Calla, R., Desautels, D., & Hasan, L. (2017). The challenges of organizational agility (part 1). *Industrial and Commercial Training*, 49(1), 6–14. <https://doi.org/10.1108/ICT-05-2016-0027>

- Arif Khan, K., & Pillania, R. K. (2008). Strategic sourcing for supply chain agility and firms' performance. *Management Decision*, 46(10), 1508–1530.
- Barahmah, M., Al-Awlaqi, M. A., AL-Tahitah, A., Habtoor, O., & Kamaruzzaman, K. (2021). The impact of strategic agility on sustainable competitive advantage in the Yemeni manufacturing industry. *Springer: ICETISI, November*, 404–416. <https://doi.org/10.1007/978-3-030-82616-1>
- Barney, J. (2002). *Gaining and sustaining competitive advantage* (2nd ed.). Prentice Hall.
- Barney, J. B. (1997). *Gaining and sustaining competitive advantage*. Addison-Wesley.
- Baskarada, S., & Koronios, A. (2018). The 5S organizational agility framework: a dynamic capabilities perspective. *International Journal of Organizational Analysis*, 26(2), 331–342. <https://doi.org/10.1108/IJOA-05-2017-1163>
- Battour, M., Barahma, M., & Al-Awlaqi, M. (2021). The relationship between hrm strategies and sustainable competitive advantage: Testing the mediating role of strategic agility. *Sustainability (Switzerland)*, 13(9). <https://doi.org/10.3390/su13095315>
- Bharadwaj, S. G., Varadarajan, P. R., & Fahy, J. (1993). Sustainable competitive advantage in service industries: a conceptual model and research propositions. *The Journal of Marketing*, 57(4), 83–99.
- Breznik, L., & Lahovnik, M. (2016). Dynamic capabilities and competitive advantage. *Journal of Contemporary Management Issues*, 21(Special Issue), 167–185.
- Cardeal, N., & Antonio, N. (2012). Valuable, rare, inimitable resources and organization (VRIO) resources or valuable, rare, inimitable resources (VRI) capabilities: What leads to competitive advantage? *African Journal of Business Management*, 6(37), 10159–10170.
- Chen, C. J. (2019). Developing a model for supply chain agility and innovativeness to enhance firms' competitive advantage. *Management Decision*, 57(7), 1511–1534. <https://doi.org/10.1108/MD-12-2017-1236>
- Cooper, Z., Gibbons, S., Jones, S., & Mcguire, A. (2011). Does hospital competition save lives? Evidence from the English NHS patient choice reforms. *Economic Journal*, 121(554), 228–260. <https://doi.org/10.1111/j.1468-0297.2011.02449.x>
- Creswell, J. W., & Creswell, J. D. (2018). *Research design* (5th ed.). Sage.
- Dagnino, G. B., Picone, P. M., & Ferrigno, G. (2020). Temporary competitive advantage: a state-of-the-art literature review and research directions. *International Journal of Management Reviews*, 23(1), 85–115.
- Eisenhardt, K. M., & Bingham, C. B. (2017). Superior Strategy in entrepreneurial settings: thinking, doing, and the logic of opportunity. *Strategy Science*, 2(4), 246–257. <https://doi.org/10.1287/stsc.2017.0045>

- Eisenhardt, K. M., & Martin, J. A. (2000). Dynamic capabilities: What are they? *Strategic Management Journal*, 21(10–11), 1105–1121. [https://doi.org/10.1002/1097-0266\(200010/11\)21:10/11<1105::AID-SMJ133>3.0.CO;2-E](https://doi.org/10.1002/1097-0266(200010/11)21:10/11<1105::AID-SMJ133>3.0.CO;2-E)
- Galvin, P., Rice, J., & Liao, T. S. (2014). Applying a Darwinian model to the dynamic capabilities view: Insights and issues. *Journal of Management and Organization*, 20(2), 250–263.
- Glassman, A. M., Zell, D., & Duron, S. (2015). Thinking strategically in turbulent times: An inside view of strategy making. *Journal of Chemical Information and Modeling* 53(9). Routledge. <https://doi.org/10.1017/CBO9781107415324.004>
- Gudwani, A., Mitra, P., Puri, A., & Vaidya, M. (2012). *India healthcare : inspiring possibilities , challenging journey* (Issue December).
- Hemmati, M., Feiz, D., Jalilvand, M. R., & Kholghi, I. (2016). Development of fuzzy two-stage DEA model for competitive advantage based on RBV and strategic agility as a dynamic capability. *Journal of Modelling in Management*, 11(1), 288–308. <https://doi.org/10.1108/JM2-12-2013-0067>
- Hoffman, N. P. (2000). An examination of the ‘sustainable competitive advantage’ concept: past, present, and future. *Academy of Marketing Science Review*, 2000(4), 1–16.
- Hossain, M. S., Kannan, S. N., & Raman Nair, S. K. K. (2021). Factors influencing sustainable competitive advantage in the hospitality industry. *Journal of Quality Assurance in Hospitality and Tourism*, 22(6), 679–710. <https://doi.org/10.1080/1528008X.2020.1837049>
- Karman, A., & Savanevičienė, A. (2020). Enhancing dynamic capabilities to improve sustainable competitiveness: insights from research on organisations of the Baltic region. *Baltic Journal of Management*. <https://doi.org/10.1108/BJM-08-2020-0287>
- Karman, A., & Savanevičienė, A. (2021). Enhancing dynamic capabilities to improve sustainable competitiveness: insights from research on organisations of the Baltic region. *Baltic Journal of Management*, 16(2), 318–341. <https://doi.org/10.1108/BJM-08-2020-0287>
- KHF. (2018). *Challenges in Kenya’s healthcare systems*. Kenya Healthcare Federation; Kenya Healthcare Federation.
- KMPDC. (2020). *Licensed HealthFacilities As 06/07/2020*. Health Institutions Register; KPMDC.
- KMPDC. (2021). *Licensed HealthFacilities As 26/03/2021*. Health Institutions Register; KPMDC.
- KMPDC. (2022). *Licensed HealthFacilities As 26/03/2021*. Health Institutions Register; KPMDC.
- Kotter, J. P. (2014). *Accelerate: Building Strategic Agility for a Faster-Moving World*. Harvard Business Review Press. <https://doi.org/10.1017/CBO9781107415324.004>

- Li, R., Peng, C., Koo, B., Zhang, G., & Yang, H. (2021). Obtaining sustainable competitive advantage through collaborative dual innovation: empirical analysis based on mature enterprises in eastern China. *Technology Analysis and Strategic Management*, 33(6), 685–699. <https://doi.org/10.1080/09537325.2020.1839043>
- Longo, F., Siciliani, L., Moscelli, G., & Gravelle, H. (2019). Does hospital competition improve efficiency? The effect of the patient choice reform in England. *Health Economics (United Kingdom)*, 28(5), 618–640. <https://doi.org/10.1002/hec.3868>
- Mahdi, O. R., & Nassar, I. A. (2021). The business model of sustainable competitive advantage through strategic leadership capabilities and knowledge management processes to overcome covid-19 pandemic. *Sustainability (Switzerland)*, 13(17), 1–27. <https://doi.org/10.3390/su13179891>
- Mariita, A. (2019). *Kenya's Health Structure And The Six Levels Of Hospitals*. Action for Transparency; Action for Transparency.
- Mazzoni, L., Lazeretti, L., & Innocenti, N. (2021). Entrepreneurship, complexity and the emergent order in the techno-economic scenario of the twenty-first century. Evidence from a field study in Tuscany. *Industry and Innovation*, 28(5), 1–24.
- Miles, J. A. (2012). *Management and organization theory*. Wiley and Sons.
- Muga R., Kizito P., Mbayah M., G. T. (1999). Overview of the Health System in Kenya. *Kenya Service Provision Assessment Survey 2004, Kspa*, 13–24.
- Nejatian, M., Zarei, M. H., Rajabzadeh, A., Azar, A., & Khadivar, A. (2019). Paving the path toward strategic agility. *Journal of Enterprise Information Management*, 32(4), 538–562.
- Netherlands Enterprise Agency. (2016). Kenyan healthcare sector: Market study report. In *Netherlands Enterprise Agency*. Netherlands Enterprise Agency.
- Nurcholis, L. (2019). The mediating effect of knowledge exploitability and organizational agility on the relationship between marketing adaptation strategy and sustainable competitive advantage. *Contaduría y Administración*, 66(1), 231. <https://doi.org/10.22201/fca.24488410e.2020.2393>
- Panayides, P. M., & Lun, Y. V. (2009). The impact of trust on innovativeness and supply chain performance. *International Journal of Production Economics*, 122(1), 35–46.
- Pereira, V., Mellahi, K., Temouri, Y., Patnaik, S., & Roohanifar, M. (2018). Investigating dynamic capabilities, agility and knowledge management within EMNEs-longitudinal evidence from Europe. *Journal of Knowledge Management*, 23(9), 1708–1728. <https://doi.org/10.1108/JKM-06-2018-0391>
- Peteraf, M. A., & Maritan, C. (2007). Dynamic capabilities and organizational agility. *California Management Review*, 58(4), 30–45.
- Porter, M. E. (1985). *Competitive advantage: creating and sustaining superior performance*. The Free Press. <https://doi.org/10.1007/978-3-319-54540-0>

- Prabowo, C. A., Manarung, A. H., Heriyati, P., & Kosasih, W. (2021). The influence of dynamic capability on sustainable competitive advantage: an empirical study of small businesses in Indonesia. *Journal of Asian Finance, Economics and Business*, 8(4), 809–817. <https://doi.org/10.13106/jafeb.2021.vol8.no6.0949>
- Saunders, P. L., & Thornhill, A. (2016). *Research methods for business students*, 7th Edition.
- Schuling, G. (2014). Changing leadership dynamics at agility-critical interfaces: action research as a 25-year longitudinal study. *Research in Organizational Change and Development*, 22, 219–297.
- Siciliani, L., & Straume, O. R. (2019). Competition and equity in health care markets. *Journal of Health Economics*, 64, 1–14. <https://doi.org/10.1016/j.jhealeco.2018.12.002>
- Singh, H., Dey, A. K., & Sahay, A. (2020). Exploring sustainable competitive advantage of multispecialty hospitals in dynamic environment. *Competitiveness Review*. <https://doi.org/10.1108/CR-12-2018-0091>
- Singh, J., Sharma, G., Hill, J., & Schnackenberg, A. (2013). Organizational agility: What it is, what it is not, and why it matters. *Academy of Management Proceedings*, 2013(1), 1–40.
- Singh, V., Vaibhav, S., & Sharma, S. K. (2018). Using structural equation modelling to assess the sustainable competitive advantages provided by the low-cost carrier model: The case of Indian airlines. *Journal of Indian Business Research*. <https://doi.org/10.1108/JIBR-12-2017-0260>
- Sousa, F. J. (2010). *Organizational culture, Business to business relationships, and interfirm networks* (A. G. Woodside (ed.); 1st ed.). Emerald Group Publishing Limited.
- Sune, A., & Gibb, J. (2015). Dynamic capabilities as patterns of organizational change. *Journal of Organizational Change Management*, 28(2), 213–231.
- Swafford, P. M., Ghosh, S., & Murthy, N. (2008). Achieving supply chain agility through IT integration and flexibility. *International Journal of Production Economics*, 116(2), 288–297.
- Teece, D. (2007). Explicating dynamic capabilities: The nature and microfoundations of (sustainable) enterprise performance. *Strategic Management Journal*, 28, 1319–1350.
- Teece, D., Peteraf, M. A., & Maritan, C. (2016). Dynamic capabilities and organizational agility. *California Management Review*, 58(4), 30–45.
- Teece, D., Pisano, G., & Shuen, A. (1997). Dynamic capabilities and strategic management. *Strategic Management Journal*, 18(7), 509–533.
- Torres, A. I., Ferraz, S. S., & Santos-Rodrigues, H. (2018). The impact of knowledge management factors in organizational sustainable competitive advantage. *Journal of Intellectual Capital*, 19(2), 453–472. <https://doi.org/10.1108/JIC-12-2016-0143>
- Vecchiato, R. (2015). Creating value through foresight: first mover advantages and strategic agility. *Technological Forecasting and Social Change*, 101, 25–36.

- Weber, Y., & Tarba, S. Y. (2014). Strategic agility: a state of the art introduction to the special section on strategic agility. *California Management Review*, 56(5), 5–12.
- Winter, S. G. (2013). Habit, deliberation, and action: strengthening the microfoundations of routines and capabilities. *The Academy of Management Perspectives*, 27(2).
- Wischnevsky, D. J. (2004). Change as the winds change: the impact of organizational transformation on firm survival". *Organizational Analysis*, 12(4), 361–377.
- Worley, C. G., Williams, T. D., & Lawler III, E. E. (2014). *The agility factor: Building adaptable organizations for superior performance*. Jossey-Bass.
- Yang, C., & Liu, H. (2012). Boosting firm performance via enterprise agility and network structure. *Management Decision*, 50(6), 1022–1044.
- Yildiz, T., & Aykanat, Z. (2021). The mediating role of organizational innovation on the impact of strategic agility on firm performance. *World Journal of Entrepreneurship, Management and Sustainable Development*, 17(4), 765–786. <https://doi.org/10.1108/WJEMSD-06-2020-0070>
- Zikmund, W. G., Carr, J. C., Babin, B., & Griffin, M. (2013). *Business research methods* (8th ed.). Nelson Education.
- Zitkiene, R., & Deksnys, M. (2018). Organizational agility conceptual model. *Montenegrin Journal of Economics*, 14(2), 115–129. <https://doi.org/10.14254/1800-5845/2018.14-2.7>
- Zuñiga-Collazos, A., Palacio, M.C. & Padilla-Delgado, L.M. (2019). Organizational competitiveness: the conceptualization and its evolution. DOI:[10.15640/jthm.v7n1a19](https://doi.org/10.15640/jthm.v7n1a19)